

TSIII SA Implant System

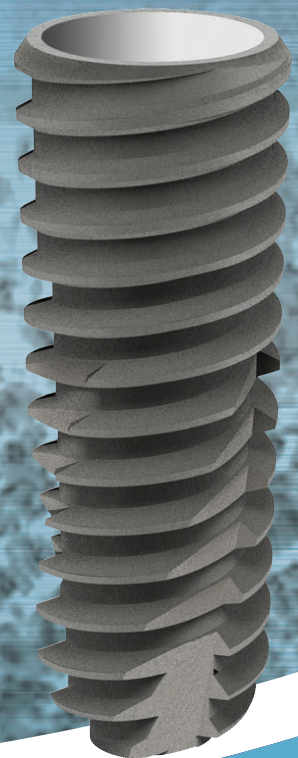

OSSTEM[®]
IMPLANT

OSSTEM SA surface

OSSTEM SA Surface

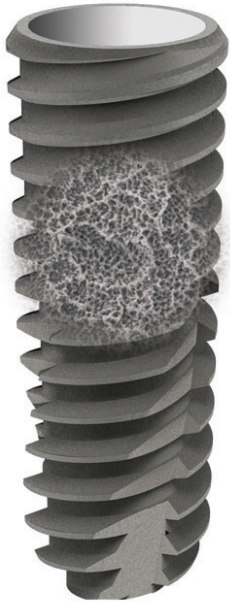

OSSTEM[®] SA Surface IMPLANT

SA : Sand blasted with alumina and Acid etched surface

- Optimal morphology : Combination of crater and micro-pit
- Optimal surface roughness : Ra 2.5~3.0 μ m
- Early cell response : 20% faster than RBM
- Early bone healing : 20% faster than RBM
- Early loading possible after 6 weeks of placement.

OSSTEM SA & 'S' surface morphology and roughness increased by 45% compared to RBM treatment.

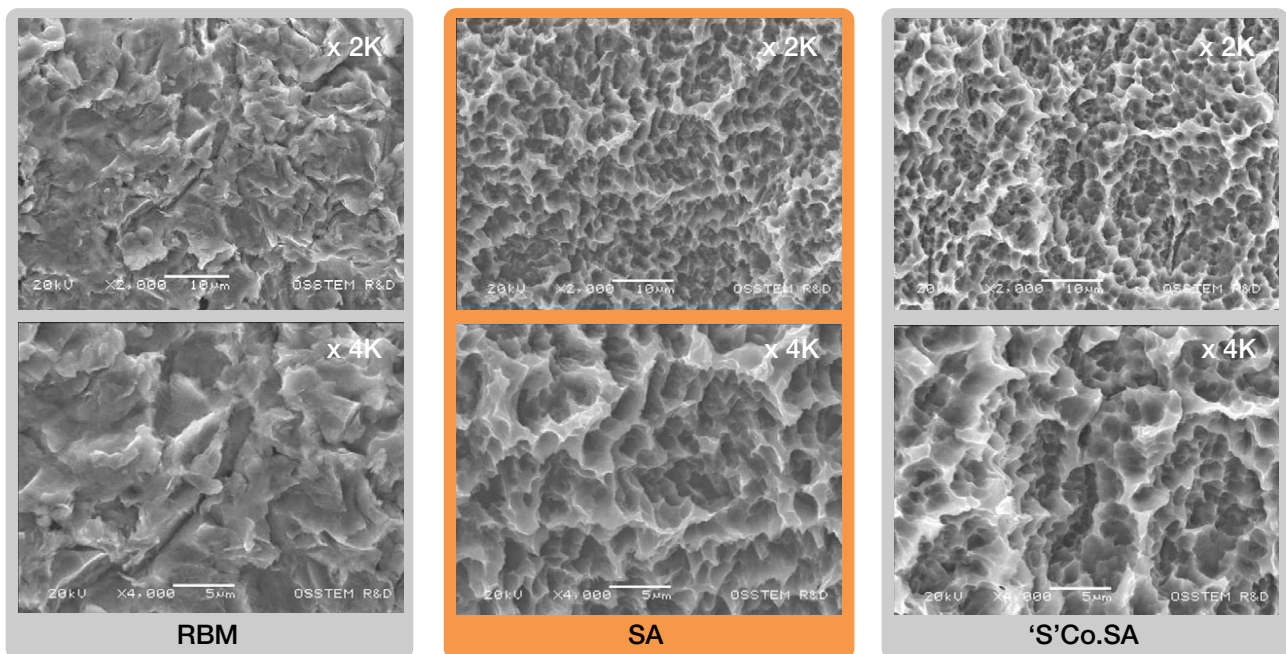

SEM (Scanning Electron Microscope) image

TSIII SA Implant overview

TSIII SA Implant overview

TSIII SA implant, developed with extensive R&D experiences of Osstem Implant, features an SA surface treatment that fully exploits the excellent pluri-potential capacity of osteoblastic cells. It shortens the bone healing time, and improves the secondary attachment force. In addition, SA surface is adopted to have a convenient placement and initial stability due to its optimal body design.

Single Pitch Micro Thread

- 0.8pitch x 0.25depth x double lead
- Synchronized thread
- Optimized design for SA surface
- Reinforce fixture strength

Corkscrew Thread

- 0.8pitch x 0.5depth x double lead
- Powerful self threading
- Keep implant path
- Easy to change the path
- High initial stability
- Decrease sensitivity on drill size

Open Thread

- Prevents bone necrosis

Helix Cutting Edge

- Powerful self threading
- Easy path change

Apical design

- Self drilling ability
- Increased initial stability at fresh extraction socket

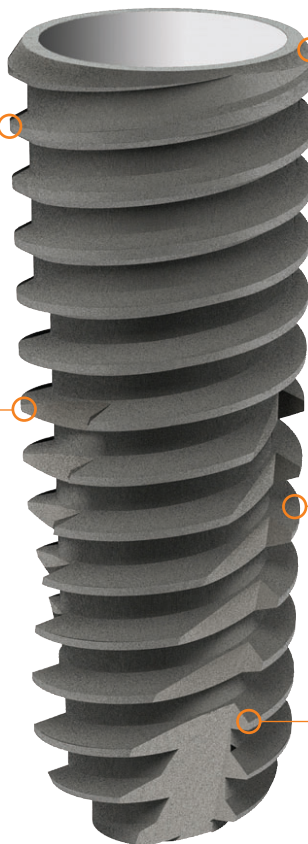

Compatibility



TSIII SA Implant overview

TSIII SA Fixture Line Up

TSIII SA Fixture has two types of abutment connection specifications: one is the Mini Connection for the $\varnothing 3.5$ fixture, and the other is the Standard Connection for other diameters. The Mini Connection must be used with separate abutment; in contrast, the Standard Connection can be used with the same abutment for fixtures more than $\varnothing 4.0$ regardless of the diameter.

Mini ($\varnothing 3.5$)

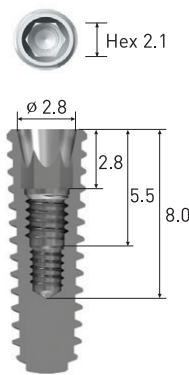

Regular ($\varnothing 4.0 / \varnothing 4.5 / \varnothing 5.0$)

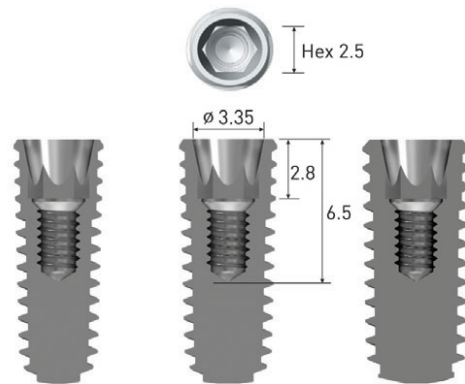

Pre-mounted Fixture (Simple Mount)

Fixture + Mount + Cover Screw : **B** + Product Code (ex: **BTS3S4011S**)

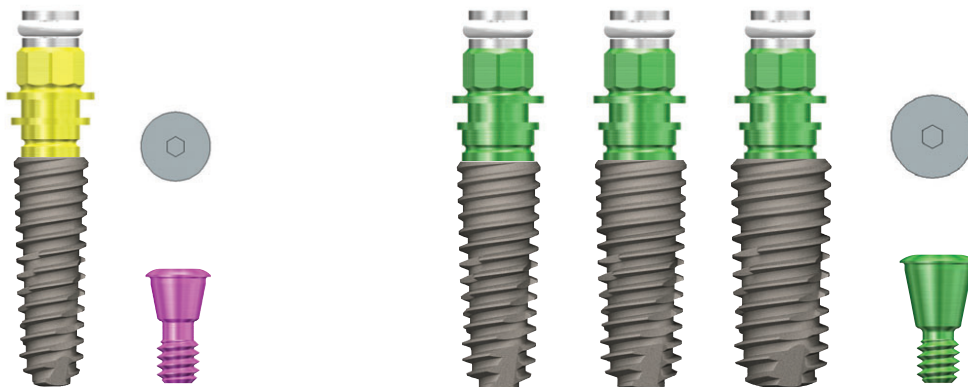

TSIII SA Fixture 3.5
(Yellow/Purple)

TSIII SA Fixture 4.0/4.5/5.0
(Green/Green)

TSIII SA Implant overview

TSIII SA Fixture Line Up

M **R** Connection

* The following labeled dimension may differ from the actual dimension.

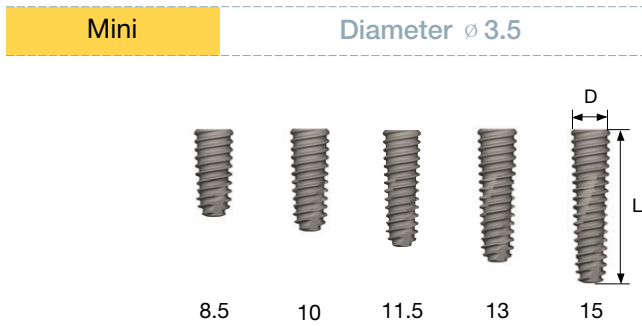

Connection		Mini
L \ D		$\varnothing 3.5$
7		-
8.5		TS3M3508S
10		TS3M3510S
11.5		TS3M3511S
13		TS3M3513S
15		TS3M3515S

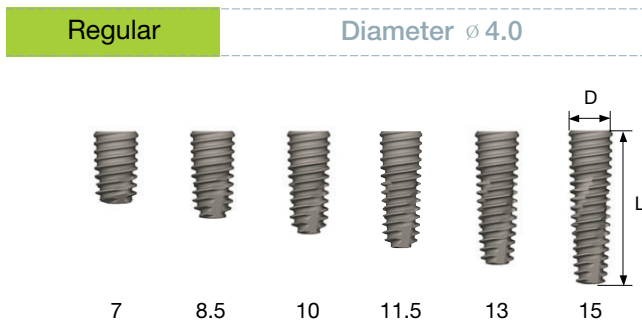

Connection		Regular
L \ D		$\varnothing 4.0$
7		TS3S4007S
8.5		TS3S4008S
10		TS3S4010S
11.5		TS3S4011S
13		TS3S4013S
15		TS3S4015S

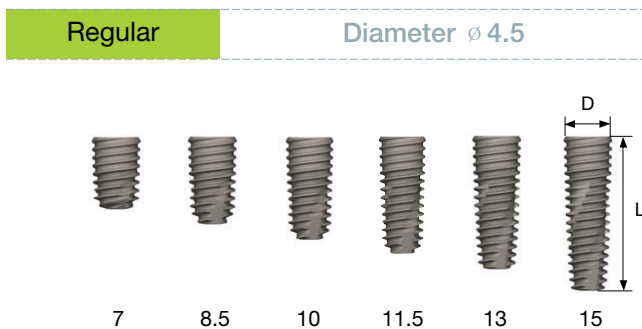

Connection		Regular
L \ D		$\varnothing 4.5$
7		TS3S4507S
8.5		TS3S4508S
10		TS3S4510S
11.5		TS3S4511S
13		TS3S4513S
15		TS3S4515S

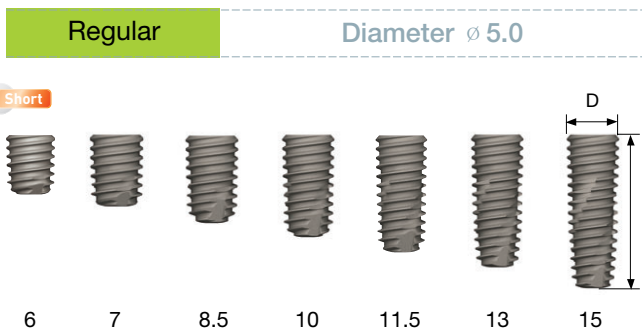

Connection		Regular
L \ D		$\varnothing 5.0$
6		TS3S5006S
7		TS3S5007S
8.5		TS3S5008S
10		TS3S5010S
11.5		TS3S5011S
13		TS3S5013S
15		TS3S5015S

TSIII Ultra-Wide Implant

TSIII Ultra-Wide SA Implant

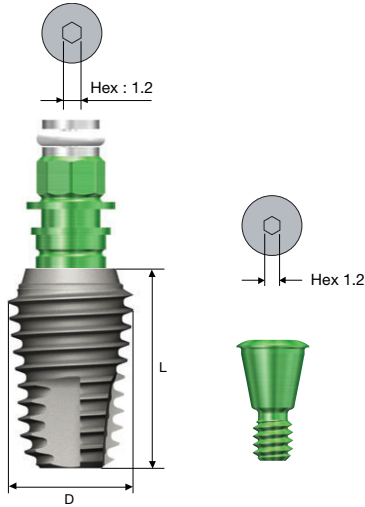

TSIII Ultra - Wide® Fixture Order Code

Fixture Only

- Fixture : Product Code [ex : TS3S6010S]

Pre-Mounted Fixture [Simple Mount]

- Fixture + Simple Mount + Cover Screw : B + Fixture Product Code
[ex : BTS3S6010S]

Regular

Diameter ϕ 6.0

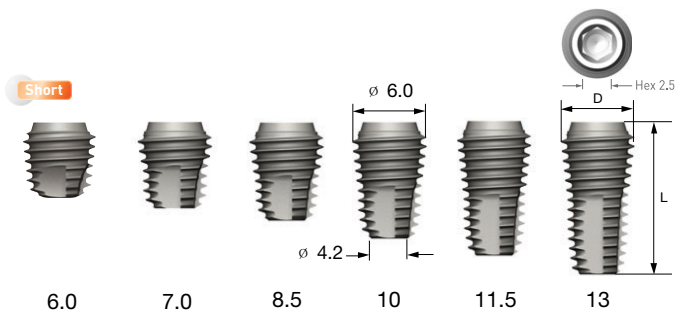

Connection		Regular
L	D	ϕ 6.0
6		TS3S6006S
7		TS3S6007S
8.5		TS3S6008S
10		TS3S6010S
11.5		TS3S6011S
13		TS3S6013S

Regular

Diameter ϕ 7.0

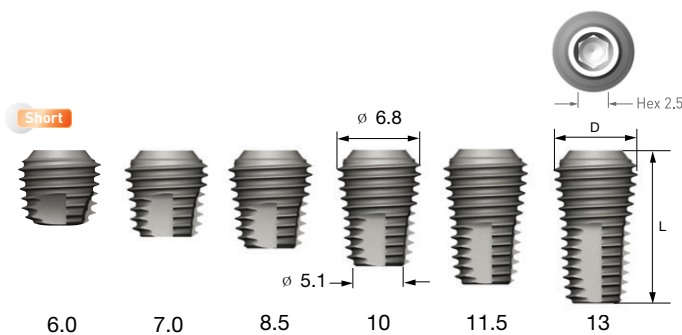

Connection		Regular
L	D	ϕ 7.0
6		TS3S7006S
7		TS3S7007S
8.5		TS3S7008S
10		TS3S7010S
11.5		TS3S7011S
13		TS3S7013S

Features of TSIII Ultra-Wide

- SA (Sand blasted with alumina and Acid etched) Surface Treatment (Ra 2.5~3.0 μ m)
- Submerged wide diameter fixture with Internal hex connection
- Compatible with GS Regular abutment components
- Useful for immediate placement for posterior and replacing failed implants
- Optimal apex design allows the implants to achieve ideal initial stability
- Rigid motion with superstructure helps maintain stable connection
- Recommended Torque : below 40Ncm
- The actual length of TSIII Ultra-Wide Fixture is 0.5mm shorter than actual length. (Exception 7mm)

TSIII SA Implant overview

TSIII SA Packing System

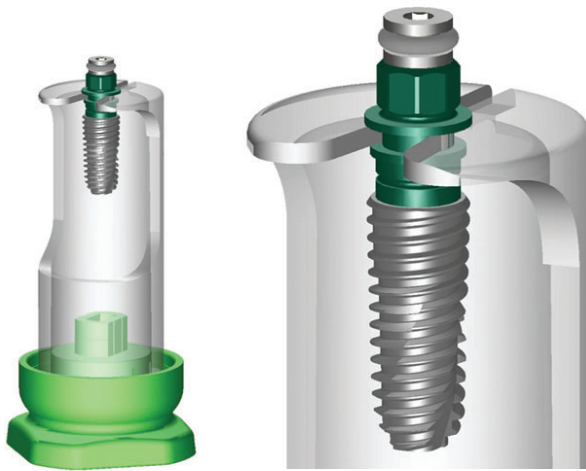

Mini : Yellow



Regular : Green



● New Ampoule User's Guide

- Applying: Grip type ampoule to protect TS III SA surface



1. Remove the back of blister (sterilized condition is not guaranteed once the blister is removed).

2. Remove the Capsule by rotating

3. Connect Driver; clicks when properly connected

4. Remove Fixture from grip holding



Edition 01/2013

TSIII SA Implant System

OSSTEM[®]
IMPLANT

OSSTEM Germany GmbH
Mergenthalerallee 25
D-65760 Eschborn
Tel: +49 (0) 61 96 / 777 55 - 0
Fax: +49 (0) 61 96 / 777 55 - 29
www.osstem.de
www.sinuskit.com

Manufacturer
#507-8, Geoje3-dong, Yeonje-gu
Busan, Korea Zip: 611-804
Tel: +82 51 850 2500
Fax: +82 51 861 46 93